



Pressure switch PSH

Description

The differential pressure sensor informs about a decrease in air flow due to a pressure difference, e.g.: a dirty filter or a defective fan, protects against overheating of electric heaters, regulation and protection in fire protection systems, protection against frost of heat exchangers. Connection cable, switching potential-free contacts.

Technical drawing

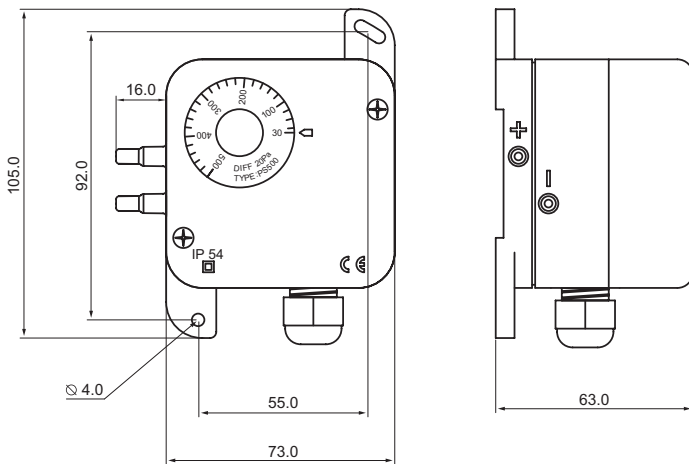

Technical specifications

Operating range	PSH 300: 30 - 300 Pa PSH 600: 40 - 600 Pa
Measurement accuracy	±8 Pa at low limit, ±15% at high limit
Switching difference	PSH 300: 25 Pa PSH 600: 35 Pa
Maximum operating pressure	50 kPa
Temperature range	operating temperature: -20 °C ... +60 °C storage temperature: -20 °C ... +85 °C
Air humidity	0...95% (relative, without condensation)
Dimensions (w x h x dpt)	90 x 105 x 63 mm
Weight	150 g
Protection class	IP54
Connections	male connector Ø 5,0 mm
Electrical connections	3 screw terminals (0,2 - 1,5 mm ²)
Power supply	250 VAC, 3 A (rez.), 2 A (ind.)

NOTE: Standard equipment includes a 2-metre PVC hose and 2 plastic connectors.

The installation of the device

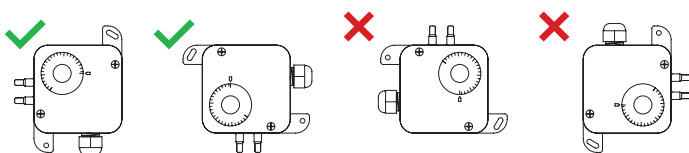

Duct temperature sensor TJK10K



Description

A duct temperature sensor, equipped with a NTCK10 thermistor (10 kΩ resistance at 25 °C) for excellent temperature stability. The measuring element was built in a special tube made of plastic. The depth of the sensor installation in the duct can be adjusted according to the needs thanks to the movable mounting flange. Protection class IP20, cable length 1.5 m.

Technical specifications

Operating range	-30 °C...+105 °C
Length	1500 mm (tube 200 mm)
Diameter	7,5 mm

Single- or two-phase heater controller HRK1



Description

HRK 1 is a microprocessor-based PID controller, designed to work only with electric heaters with a power supply of 1~230V and 2~400V (2-phase). Do not use the HRK controller to regulate the operation of electric motors, lighting and heaters with a power supply of 3~400V (3-phase). The controller is equipped with an automatic voltage detection function. The time between switching the heater on and off is automatically adjusted by the controller to maintain the set temperature. The controller has a built-in temperature sensor, but it can also work with external sensors. The air temperature value can be limited to the minimum and maximum values - this requires the connection of 2 external sensors according to the diagram. HRK1 automatically detects the connected sensors and selects the appropriate operating mode. The controller has a night mode, which allows it to reduce the set temperature by 0...10 °C. This function requires an external timer. HRK1 has an angle sensor between phase and zero to protect against RFI interference.

Technical specifications

Maximum adjustable load [kW]	6,4/400V ; 3,2/230V
Minimum adjustable load [kW]	0,4/400V ; 0,23/230V
Maximum adjustable current [A]	16
Minimum adjustable current [A]	1
Voltage [V]	230 - 415
Frequency [Hz]	50 - 60
Phases	1~230V / 2~400V
Dimensions [mm]	150 x 80 x 45
Protection class	IP20
Room temperature [°C]	30 max.
Ambient humidity	90% max
Ambient temperature [°C]	0 - 30



Three-phase heater controller HRK3

Description

HRK3 is a microprocessor-based power controller of the electric heater. Do not use the HRK3 controller to adjust the operation of electric motors and lighting. HRK3 allows you to adjust the heater with a power of up to 15kW. In addition, the regulator has a relay output with a contactor, allowing it to connect a load of 12 kW. The total allowable load of the controller is 27 kW.

HRK3 automatically adjusts the control mode to match the dynamics of the subject. In case of rapid temperature changes, e.g. ventilation temperature control, the controller will work as a PI (proportional-integral) type regulator. For slow temperature changes, e.g. room temperature control, the controller will operate as a P (proportional) regulator. The controller has a night mode, which allows it to lower the set temperature by 0..10°C. This function requires an external timer.

Technical specifications

Maximum adjustable load [kW]	15
Extra adjustable load [kW]	12
Total adjustable load [kW]	27
Maximum adjustable current [A]	25
Voltage [V]	3x230 / 3x400
Frequency [Hz]	50 - 60
Phases	3~
Dimensions [mm]	105 x 260 x 120
Fuse [A]	2 x 0,315
Protection class	IP20
Room temperature [°C]	0 - 40
Ambient humidity	90% max
Heat dissipation [W]	50



External temperature setpoint HR5K

Description

The HR5K external temperature setpoint can be used with HRK1 and HRK3 controllers as a remote temperature setting point. HR5K is used when the installation of the regulator in a given location is impossible for safety, aesthetic or other reasons resulting from the design. Surface-mounted.

Technical specifications

Potentiometer	5 kΩ
Setting range	0..30°C
Protection class	IP20
Dimensions [H x W x Dpt]	71 x 71 x 25 mm

Electrical room thermostat HTS



Description

The thermostat can be used to adjust both heating and cooling. Temperature measurement by internal or external sensor. Selectable set point range and sensor hysteresis.

The external temperature sensor must be purchased separately.

Technical specifications

Input voltage	230V
Relay output	6A / 230V
Cycles	60000
Hysteresis	1..3°C
Adjustment range	0..30°C lub 0..60°C
External temperature sensor	TJK 10K (NTC 10K 10kΩ @ 25°C)
Insulation class	II
Protection class	IP20
Cover material	Material from group IIIa
Dimensions (H x W x Dpt)	71 x 71 x 25 mm
Ambient humidity	90% max
Heat dissipation [W]	50

Electronic speed controller HRX



Description

The electronic fan speed controller for single-phase motors enables smooth adjustment of the efficiency of the control panel or a fan. Surface or flush mounting possible.

Technical drawing

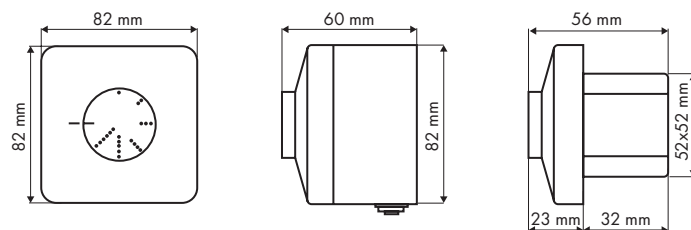

Technical specifications

Model	Voltage [V]	Current [A]	Weight [kg]
HRX 1.0	1x230	1,0	0,32
HRX 2.5	1x230	2,5	0,32
HRX 4.0	1x230	4,0	0,32



Potentiometer for EC motors HMTP

Description

The HMTP potentiometer has been developed to control devices that need a stageless control signal. Supply voltage range 0–12 VDC. The output voltage is infinitely adjustable from 0 to the supply voltage (U_s) by a knob. It is equipped with a switch (potential-free contact) for remote switching on/off of external devices. The potentiometer is suitable for flush mounting (IP44) and surface mounting (IP54).

Technical specifications

Supply voltage (U_s)	max. 12 VDC / 1 mA
Output	0– U_s
Contact switch rating	4 A (250 VAC) 10 A / 12 VDC
Protection class	IP44 / IP54 (according to EN 60529)
Environmental conditions	Temperature 0–50 °C Humidity <95 % rH (non-condensing)

Connections



U_s	Supply voltage (0–12 VDC)
+	Output voltage (0– U_s)
-	Grounding
σ_1	Non-voltage contact for remote ON/OFF of external devices
Connections	Cable cross-section: max. 2,5 mm ²

Technical drawing

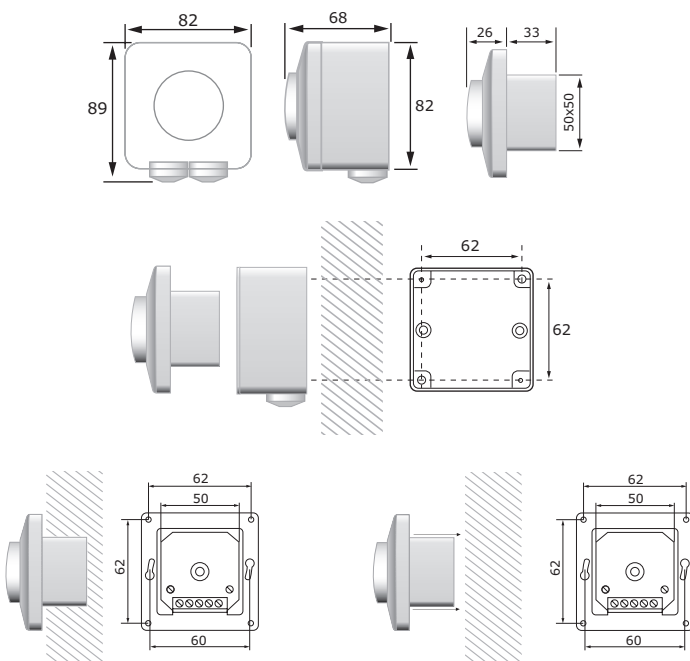

Speed controller for EC motors RS-EC



Description

The controller is designed for smooth control of fans with EC motors. Quick connection of the fan with the controller via the “Jack” plug. Flush mounting possible.

Technical drawing

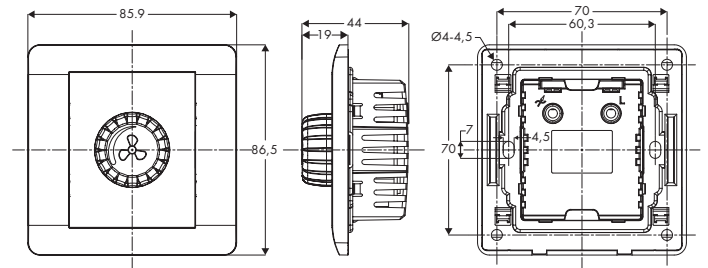

Technical specifications

Model	Control voltage [V]	Weight [kg]
Regulator RS-EC	0 - 10	0,1

Single-phase motor gear switch HRS

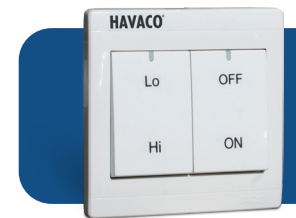

Description

The gear switch is designed to control the speed of fans with two-speed single-phase motors. Operating status: on/off and first/second gear.

Technical specifications

Model	Voltage [V]	Max. current [A]	Weight [kg]
HRS-01	230	10	0,1

Technical drawing

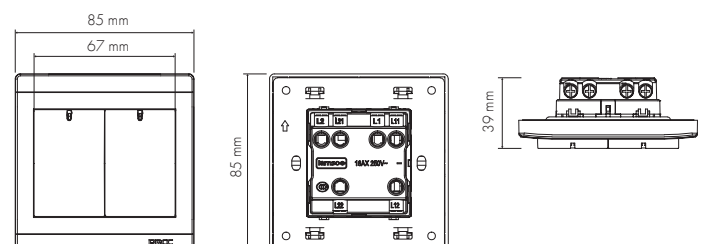



Transformer speed controller HRB

Description

Transformer controllers are adapted to change the motor speed by changing the voltage. The controllers have a function to protect against overheating of the transformer. All regulators have a 230 VAC output to connect actuators, heaters, relays, integrating the work of accessories with the work of the fan. More than one fan may be connected to a single controller, provided that the total current of all motors does not exceed the maximum permissible value of the controller.

Technical drawing

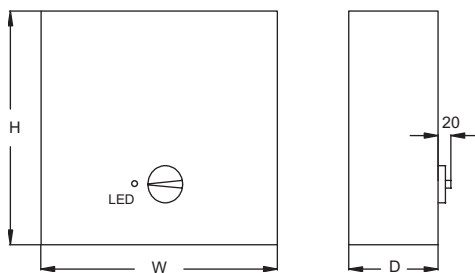

Technical specifications

Model	Voltage [V]	Max. current [A]	Weight [kg]	Dimensions HxWxD [mm]
HRB 1	1x230	1,0	1,9	165x120x79
HRB 1,5	1x230	1,5	2,6	165x120x79
HRB 2	1x230	2,0	3,0	170x145x93
HRB 3	1x230	3,0	3,5	170x145x93
HRB 4	1x230	4,0	4,4	178x155x150
HRB 5	1x230	5,0	4,9	178x155x150
HRB 7	1x230	7,0	7,3	244x184x178

Number of regulation steps	5
Power supply	1x230 VAC
Frequency	50-60 Hz
Voltage values	80V $I_{max} * 0,6$; 120V $I_{max} * 0,8$; 140V $I_{max} * 1$; 170V $I_{max} * 1$; 230V $I_{max} * 1$
Protection class	IP44
Max. ambient temperature	40 °C
Max. allowable temperature	T = 130 °C – ambient temperature. Max. transformer temperature 70 °C, limited by thermal protection of the transformer.

Transformer speed controller HRC/HRT

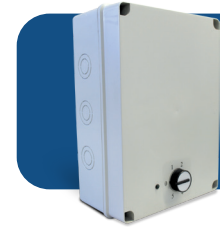

Description

Transformer controllers are adapted to change the motor speed by changing the voltage. The controllers have a function to prevent overheating of both the motor and the transformer. All controllers have a 230 VAC output to connect actuators, heaters, relays, integrating the work of accessories with the work of the fan. More than one fan may be connected to a single controller, provided that the total current of all motors does not exceed the maximum permissible value of the controller.

The 3-phase motor regulators are protected against power loss. When the power is restored, the controller will not return to the selected gear – the controller must be switched off and on again.

Technical drawing

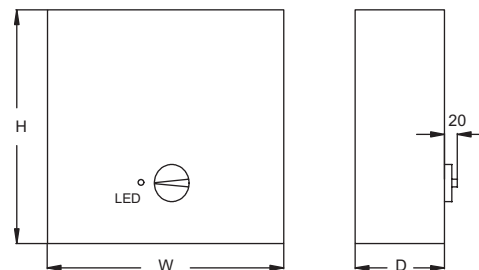

Technical specifications

Model	Voltage [V]	Max. current [A]	Weight [kg]	Dimensions HxWxD [mm]
HRC 1,5	1x230	1,5	2,6	178x155x99
HRC 2	1x230	2,0	3,0	178x155x99
HRC 3	1x230	3,0	3,5	178x155x99
HRC 4	1x230	4,0	4,4	178x155x150
HRC 5	1x230	5,0	4,9	178x155x150
HRC 7	1x230	7,0	7,3	244x184x178
HRC 11	1x230	11,0	9,5	244x184x178
HRC 14	1x230	14,0	10,4	244x184x178
HRT 1	3x400	1,0	6,3	335x245x133
HRT 2	3x400	2,0	8,1	335x245x133
HRT 3	3x400	3,0	10,7	335x245x133
HRT 4	3x400	4,0	14,6	335x245x133
HRT 5	3x400	5,0	18,7	300x290x160
HRT 7	3x400	7,0	24,7	365x320x190
HRT 11	3x400	11,0	34,1	365x320x190
HRT 14	3x400	14,0	37,2	365x320x190

Number of regulation steps	5
Power supply	HRC - 1x230 VAC, HRT – 3x400 VAC
Frequency	50-60 Hz
Voltage values	80V $I_{max} * 0,6$; 120V $I_{max} * 0,9$; HRC: 140V $I_{max} * 1$; 170V $I_{max} * 1$; 230V $I_{max} * 1$; 130V $I_{max} * 0,9$; 170V $I_{max} * 1$; HRT: 220V $I_{max} * 1$; 270V $I_{max} * 1$; 400V $I_{max} * 1$
Protection class	IP44
Max. ambient temperature	40 °C



Service switch WSH

Description

The service switch WSH is designed for fans and HVAC devices (e.g. roof fans, duct fans, box fans, ventilation units, etc.). The WSH switch is equipped with additional contacts (NO and NC). Mounting method - surface-mounted. KD rubber grommets (seals) available as additional accessories. IP 65 protection class.

Product code

Product code	Operating current AC21A*	Output power 400 VAC/AC3*	Poles	NO contact	NC contact
WSH 20	20 A	5,5 kW	4	1	1

* Reminder:

AC21A - Switching of resistive loads, including small loads.

AC3 - Electric motors with a squirrel-cage rotor: starting, stopping, control.

Technical drawing [mm]

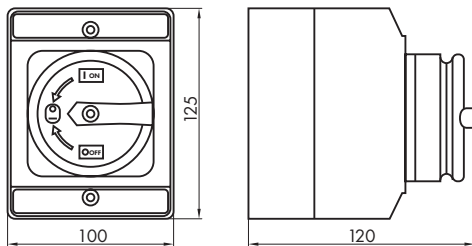

Main characteristics:

- 90° switching angle.
- Easy to connect through M20 holes.
- Clamping screws in open position.
- Triple "off" position with padlock protection.

Technical specifications

Protection class	IP65 (according to EN 60529)
Environmental conditions	Temperature: ≤ 20 - 40 °C
	Humidity: 50% rH (at +40 °C)
	≤ 90% rH (at +20 °C) non-condensing
Regulations	

Electrical connection

	14	22	1/L1	3/L2	5/L3	N
○ OFF	13	21	2/T1	4/T2	6/T3	N
I ON	X		X	X	X	X

Switch diagram



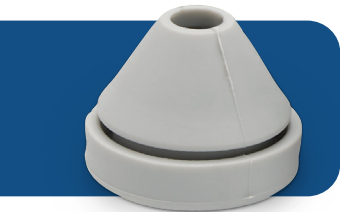

Rubber gland KD

Description

KD is a general purpose grommet for tight connection of cables with service switches WSH, etc., protection class IP67. They are made of high quality rubber resistant to dust and solvents. Metric size M20.

Technical drawing [mm]

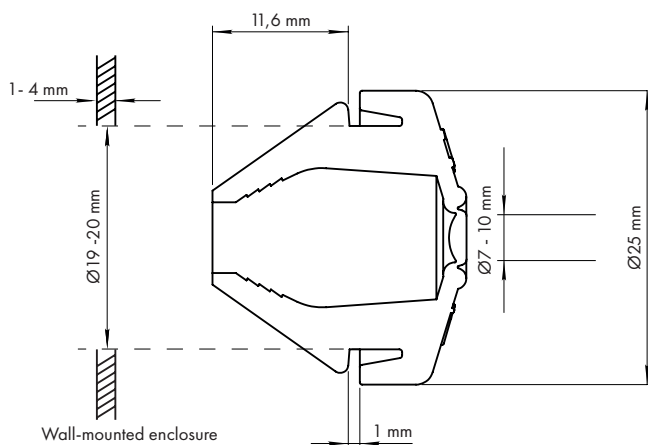

Technical specifications

Material	TPV rubber
Protection class	IP67 (according to EN 60529)
Temperature range	-60 - 135 °C
Sealing range	7 - 10 mm
Colour	Grey (RAL 7035)
Regulations	Directive RoHS 2017/2102 / UE 